



It's one thing to anticipate a player's needs.

It's more important to anticipate those needs before they arise.

Only one company has the proven foresight necessary to deliver on that promise.

WMS presents

BLUEBIRD 





With the introduction of the BLUEBIRD[®]2 cabinet, WMS has once again upped the ante for the entire industry. Building on the ergonomically advanced original BLUEBIRD cabinet and our player-favorite brands, proven intellectual property and gameplay mechanics, BLUEBIRD2 takes the gaming experience to

a whole new level.

The BLUEBIRD2 is even sleeker than its predecessor,

with a slender $21.5 \text{ in}/54.6 \text{ cm}$ profile.





Quick-release

laminated panels combined with

tool-free access

to all major peripherals creates superb speed

and ease of service and maintenance.





A powerful draw

Visually eye-catching dual twenty-two inch widescreen HD displays dominate BLUEBIRD2, delivering a powerful draw as well as an engaging ride.

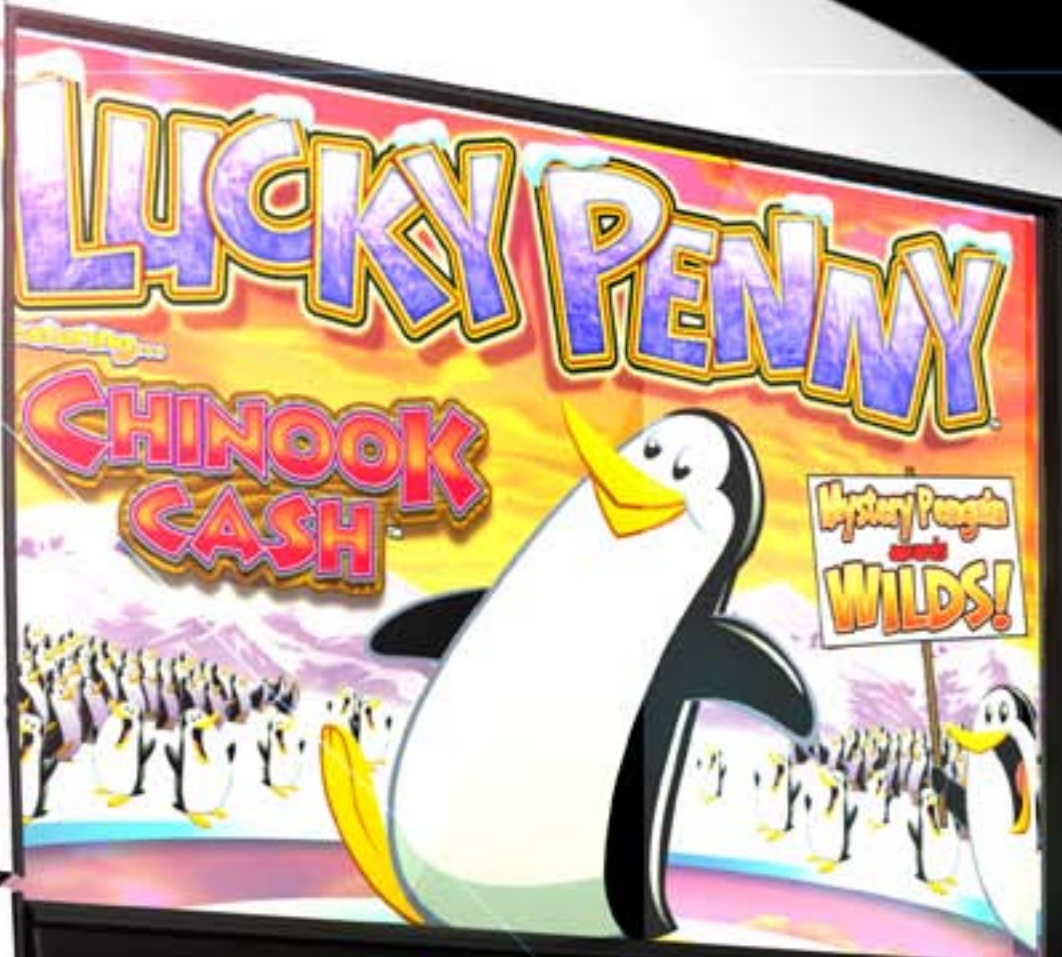

sound design

The next-generation BOSE® sound system is custom designed to enhance the BLUEBIRD2 sensory experience, delivering clean and clear treble and deep, rumbling bass.

G+

FR

BOSE

10

10





The future-ready BLUEBIRD2 is a completely digital platform.

It includes a **fully programmable button panel**

that enables all aspects of server-based gaming,

such as remote server-based configurations and downloadable content

that gives you control to be a game changer.



game changer

Driving this revolutionary product is the state-of-the-art CPU-NXT[®]2 platform, which gives BLUEBIRD2 endless design and executional options.

All of these features — dual 22" LCD screens, BOSE® sound, a fully programmable button panel, the CPU-NXT2 platform — can be found in our mechanical BLUEBIRD2, with the addition of reel mechanisms framed by a

transmissive
LCD
screen



The new BLUEBIRD2 from WMS.



Maximizing gaming today,
while preparing you for the innovations of tomorrow.

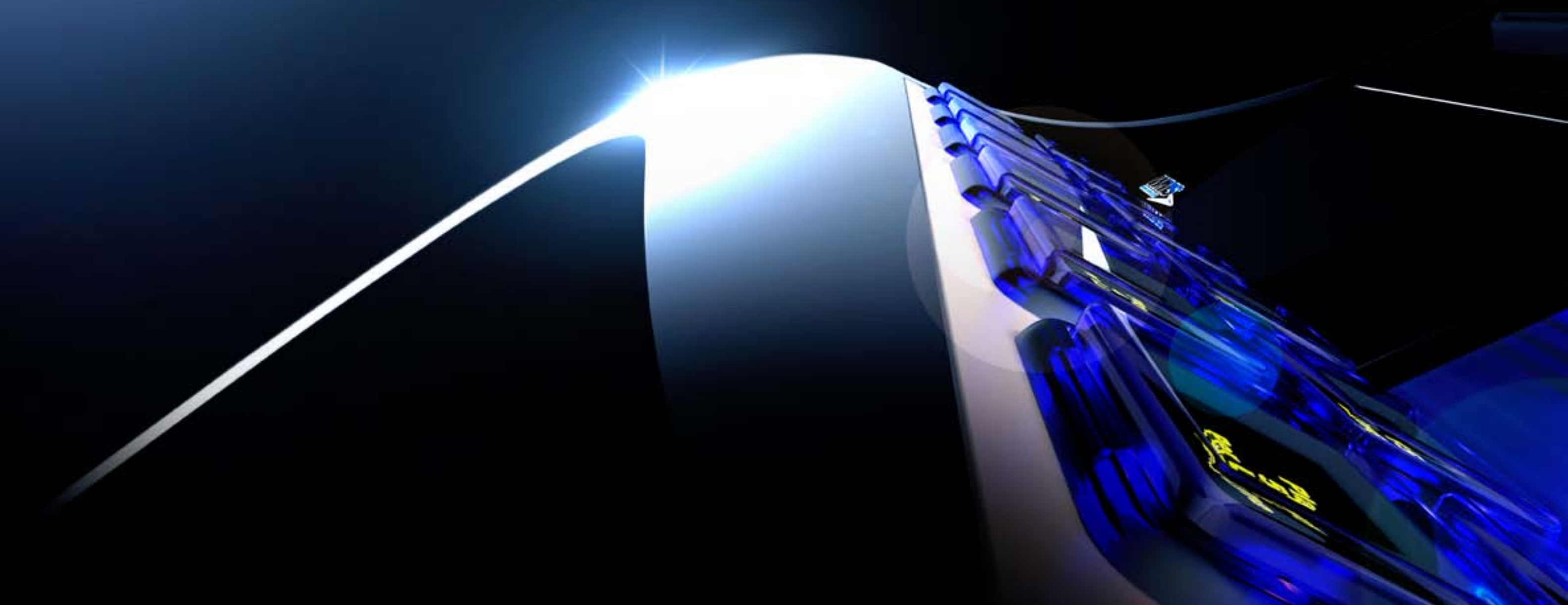



wms.com/bluebird2

BLUEBIRD®2 SPECIFICATIONS

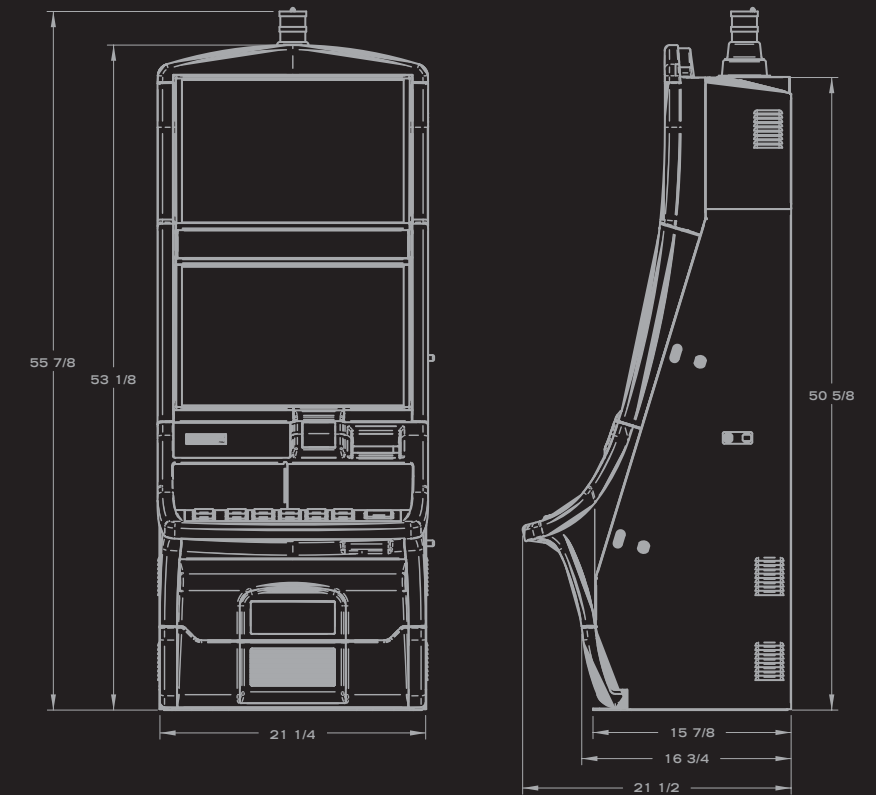

BLUEBIRD2 is loaded with features that make it one of the industry's most innovative cabinets – from quality and ergonomics to usability and supportability.

- Dual 22" widescreen high definition displays
- Dynamic and fully programmable button panel
- Completely digital platform
- Compelling BOSE® audio experience
- Slim 21½" profile
- Designed for industry standard 18" high stand
- Long life CCFL lighting
- Illuminated printer and bill acceptor bezels
- Quick release laminate panels
- Superb speed and ease of serviceability
- Allows for all aspects of server-based gaming
- Powerful CPU-NXT®2 technology platform
- Leverages existing BLUEBIRD brand loyalty

The BLUEBIRD2 Mechanical also includes:

- Transmissive LCD in bottom screen
- Reel mechanisms inside

SLIM LOOK, SMOOTH STYLE

The smooth, progressive styling of the BLUEBIRD2 cabinet puts everything on the gaming console at the fingertips of players and provides the luxury of increased legroom. The result, the most convenient and exceptionally comfortable gaming experience possible.

